

125A

STANDARD VALVE

Type 125A is the standard DN50 sampling valve by FAMAT. Used for sampling applications of powders, granules, pastes and liquids under process conditions in the pharmaceutical, chemical and food industries.



	TECHNICAL DATA
MODEL	125A
NOMINAL SIZE	DN 50 (2")
MAX. TEMPERATURE:	+180°C / +356°F
MIN. TEMPERATURE:	-10°C / +14°F
PRESSURE CLASS:	PN10
DESIGN PRESSURE:	0-10 bar / 0-145 psi
INT. ROUGHNESS:	Ra ≤0.8 μm
EXT. ROUGHNESS:	Ra ≤3.2 μm
APPL. STANDARD:	PED, ATEX, FDA
BODY MATERIAL	Stainless steel 1.4435 (316L), Hastelloy®, Titanium etc.
SEALS MATERIALS	Viton, Viton/FEP/PFA, Perfluorelastomer FFKM; EPDM (All FDA)
SAMPLE UNIT	Bottle 150 ml, glass Borosilicate with stainless steel protection
WEIGHT	10kg / 22 lbs

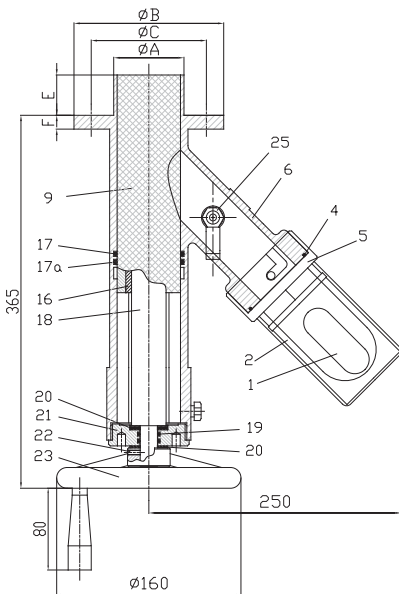

SUB ASS.	PART	NAME
	1*	Glass Bottle*
B101*	2	Protection
	5	Coupling
	4	Coupling Gasket
Set JB*	17	O-ring (2pcs)
	19	O-Ring (2pcs)
P925*	6	Body
	9	Piston
	16	Nut
Set JA*	18	Screw
	20	Washer 2 Pcs
C601*	21	Cover
	22	Pin
V2301*	23	Handwheel
A2501*	25	Venting Valve

* Recommended spare parts
 Note: the size of the connection flanges is detailed at page 28.